

# TPT-C

2+2 independent jaw movement  
Tongue & groove

High precision 2+2 jaw power chuck with self-centering independent jaw movement Ø 210 - 400 mm

- closed center
- tongue & groove



## Application/customer benefits

- Clamping of rectangular and square work pieces, self-centering in two axes

## Technical features

- 2+2 jaw chuck with 2 independent self-centering jaw drives (two wedge drives)
- jaw No. 1 + 3 (clamping jaws): power operated
- jaw No. 2 + 4 (centering jaws): spring operated or optionally power operated
- chuck body and internal parts are case hardened for high position and long life

## Standard equipment\*

2+2 jaw chuck  
Mounting bolts

## Ordering example

Power chuck TPT-C 250 A8 or  
TPT-C 400-Z

## A One wedge drive

- Operated by standard closed center cylinders.
- Jaws 2 and 4 are spring operated to center the component in one axis.
- Jaws 1 and 3 are power operated from the cylinder to center the component on the second axis and to apply the gripping force to drive the component.
- See specific draw pull, gripping force and maximum speed in the technical data table below.

## B Two independent wedge drives\*

- Operated by independent double piston cylinders.
- Jaws 2 and 4 are power operated (using the small cylinder) to center the component in one axis.
- Jaws 1 and 3 are also power operated (using the large cylinder) to center the component on the second axis and to apply the gripping force to drive the component.
- Since both pair of jaws are power operated the chuck can reach higher speeds.
- See specific draw pull, gripping force and maximum speed in the technical data table below.

\*Note: the chucks are always delivered as "one wedge drive" version: To use them as "two independent wedge drives" version, just remove the internal "spring assembly" according to instruction manual.

## Technical data

SMW-AUTOBLOK Type		TPT-C 210	TPT-C 250	TPT-C 315	TPT-C 400
Number of jaws		2+2	2+2	2+2	2+2
Radial jaw stroke	mm	4	5	5	7
Wedge stroke	mm	19	24	24	33
Weight (plain back without top jaws)	kg	21	32	48	102
Moment of inertia (m·r <sup>2</sup> )	kg·m <sup>2</sup>	0.12	0.27	0.64	1.95

## A ONE wedge drive

Max. draw pull (clamping wedge, jaw 1 + 3)	kN	29	39	45	60
Max. gripping force jaw 1 + 3 (power operated)	kN	72	98	115	150
Max. centering force jaw 2 + 4 (spring operated)	kN	11	15	15	24
Max. speed	r.p.m.	2500	2400	2000	1500
Recommended actuating cylinders	type	SIN-S 125	SIN-S 125	SIN-S 150	SIN-S 150

## B TWO independent wedge drives

Max. draw pull (clamping wedge, jaw 1 + 3)	kN	25	34	40	50
Max. draw pull (centering wedge, jaw 2 + 4)	kN	19	25	30	35
Max. gripping force jaw 1 + 3 (power operated)	kN	72	98	115	150
Max. centering force jaw 2 + 4 (power operated)	kN	55	72	85	100
Max. speed	r.p.m.	4300	3400	2700	2000
Recommended actuating cylinders	type	DCE 64/64	DCE 64/64	DCE 64/64	DCE 64/64

\*technical details of DCE cylinders see page 230

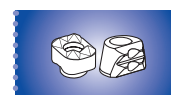

Page 310



Page 304



Page 217

# High precision 2+2 jaw power chuck with self-centering independent jaw movement Ø 210 - 400 mm

# TPT-C

- closed center
- tongue & groove

2+2 independent jaw movement  
Tongue & groove

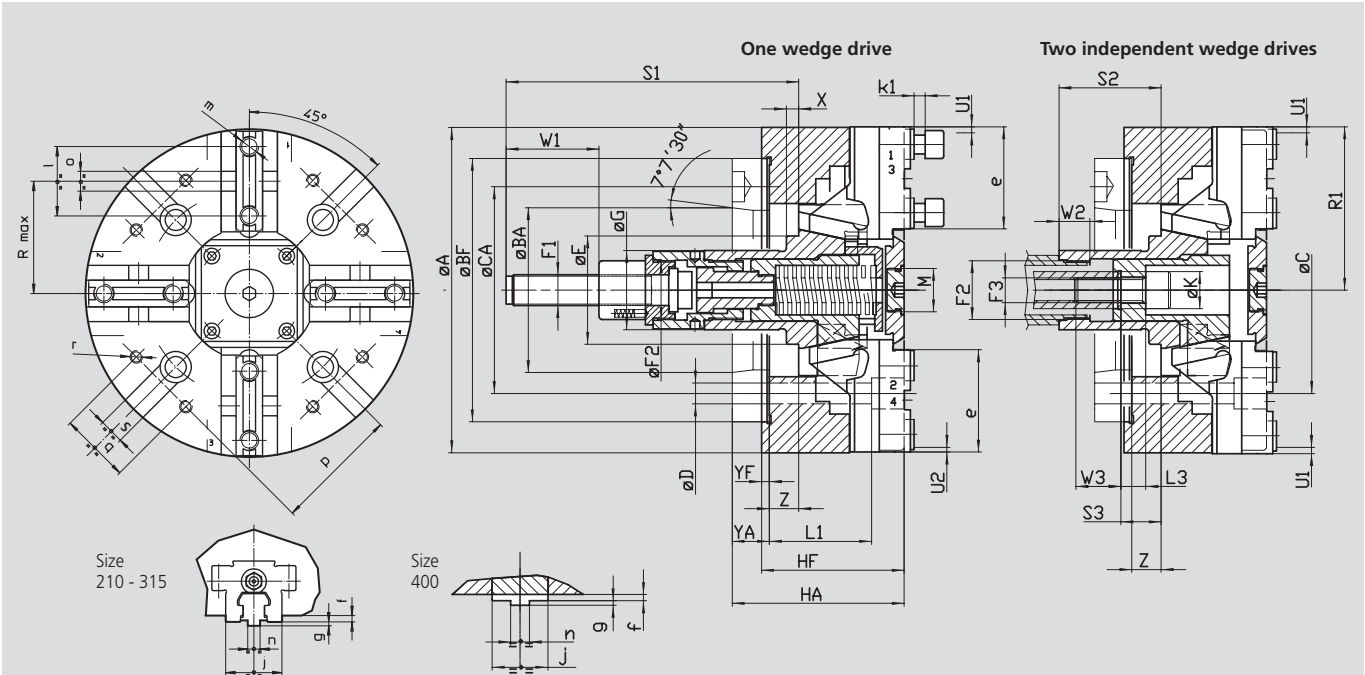

Subject to technical changes  
For more detailed information please ask for customer drawing

SMW-AUTOBLOK Type			TPT-C 210		TPT-C 250			TPT-C 315			TPT-C 400	
Mounting			FL170	A6	FL220	A6*	A8	FL300	A8*	A11	FL300	A11
	<b>A</b>	mm	210		254			315			390	
	<b>Bf/BA H6</b>	mm	170	106.375	220	106.375	139.719	300	139.719	196.869	300	196.869
	<b>C</b>	mm	133.4		171.4	-	171.4	235	-	235	235	235
	<b>CA</b>	mm	-	-	-	133.4	-	-	171.4	-	-	-
	<b>D</b>	mm	13.5		17	13.5	17	21	17	21	21	21
	<b>E</b>	mm	70		88			110			98	
	<b>F1</b>	mm	M20		M24			M24			M24	
	<b>F2</b>	mm	M38 x 1.5		M56 x 2			M56 x 2			M56 x 2	
	<b>F3</b>	mm	M16		M20			M20			M20	
	<b>G</b>	mm	51		61			61			70	
Chuck height	<b>Hf/HA</b>	mm	92	111	105	124	127	111	127	136	116	140
	<b>K H8</b>	mm	24		30			30			35	
	<b>L1</b>	mm	66		59			33			54	
	<b>L3</b>	mm	11		9			11			11	
	<b>M</b>	mm	M28 x 1.5		M28 x 1.5			M28 x 1.5			M24 x 1	
	<b>R1</b>	mm	105.5		127.5			158			196	
	<b>Rmax</b>	mm	72		88			105			133.5	
	<b>S1</b>	mm	189		203			201			218	
	<b>S2</b>	mm	61		71			69			86	
	<b>S3</b>	mm	21		33			31			45.5	
Jaw stroke (power 1 + 3)	<b>U1</b>	mm	4		5			5			7	
Jaw stroke (spring 2 + 4)	<b>U2</b>	mm	3		4			4			5.4	
	<b>W1</b>	mm	60		60			60			60	
	<b>W2</b>	mm	20		20			20			20	
	<b>W3</b>	mm	29		31			29			29	
	<b>X</b>	mm	8		8			10			10	
	<b>Yf/YA</b>	mm	5	24	5	24	27	5	30	30	6	30
Wedge stroke	<b>Z</b>	mm	19		24			24			33	
	<b>e</b>	mm	66		77.5			93			116	
	<b>f</b>	mm	4		4			4			7	
	<b>g</b>	mm	2.5		3			3			3	
	<b>j</b>	mm	36		45			45			62	
	<b>k1</b>	mm	11		12			12			14	
	<b>l</b>	mm	44.4		54			54			76.2	
	<b>m</b>	mm	M12		M16			M16			M20	
	<b>n h8</b>	mm	7.94		12.7			12.7			12.7	
	<b>o H7</b>	mm	12.68		19.03			19.03			19.03	
	<b>p</b>	mm	80		102			100			150	
	<b>q</b>	mm	45		60			60			80	
	<b>r</b>	mm	M8		M10			M10			M12	
	<b>s H8</b>	mm	16		16			20			20	
	<b>t</b>	mm	5		5			5			5	

\* Indirect mounting

# TPT-C

2+2 independent jaw movement  
Tongue & groove

High precision 2+2 jaw power chuck with self-centering independent jaw movement Ø 500 - 800 mm

- closed center
- tongue & groove

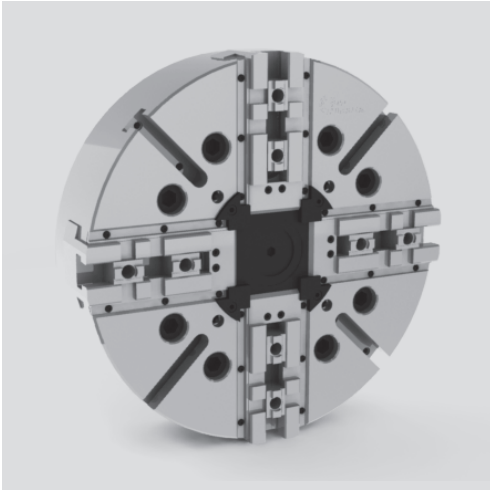

## Application/customer benefits

- Clamping of rectangular and square work pieces, self-centering in two axes

## Technical features

- 2+2 jaw chuck with 2 independent self-centering jaw drives (two wedge drives)
- jaw No. 1 + 3 (clamping jaws): power operated
- jaw No. 2 + 4 (centering jaws): spring operated or optionally power operated
- case hardened internal parts for high precision and long life
- high quality cast iron body for lightweight and durability
- protection from contamination with seals along the master jaw profiles

## Standard equipment

- 2+2 jaw chuck
- 1 set of T-nuts and bolts
- 1 set of soft top jaws
- Mounting bolts

### A One wedge drive

- Operated by standard closed center cylinders.
- Jaws 2 and 4 are spring operated to center the component in one axis.
- Jaws 1 and 3 are power operated from the cylinder to center the component on the second axis and to apply the gripping force to drive the component.
- Only for external clamping.
- See specific draw pull, gripping force and maximum speed in the technical data table below.

### B Two independent wedge drives\*

- Operated by independent double piston cylinders.
- Jaws 2 and 4 are power operated (using the small cylinder) to center the component in one axis.
- Jaws 1 and 3 are also power operated (using the large cylinder) to center the component on the second axis and to apply the gripping force to drive the component.
- Since both pair of jaws are power operated the chuck can reach higher speeds.
- See specific draw pull, gripping force and maximum speed in the technical data table below.

**\*Note:** the chucks are always delivered as "one wedge drive" version: To use them as "two independent wedge drives" version, just remove the internal "spring assembly" according to instruction manual.

## Technical data

SMW-AUTOBLOK Type		TPT-C 500	TPT-C 630	TPT-C 800
Number of jaws		2+2	2+2	2+2
Radial jaw stroke	mm	8.5	10	10
Wedge stroke	mm	32	38	38
Weight (plain back without top jaws)	kg	180	325	550
Moment of inertia (m·r <sup>2</sup> )	kg·m <sup>2</sup>	6	16	44

### A ONE wedge drive

Max. draw pull (clamping wedge, jaw 1 + 3)	kN	80	80	80
Max. gripping force jaw 1 + 3 (power operated)	kN	160	160	160
Max. centering force jaw 2 + 4 (spring operated)	kN	30	30	30
Max. speed	r.p.m.	800	630	500
Recommended actuating cylinders	type	SIN-S 175-200	SIN-S 175-200	SIN-S 175-200

### B TWO independent wedge drives

Max. draw pull (clamping wedge, jaw 1 + 3)	kN	67	67	67
Max. draw pull (centering wedge, jaw 2 + 4)	kN	50	50	50
Max. gripping force jaw 1 + 3 (power operated)	kN	160	160	160
Max. centering force jaw 2 + 4 (power operated)	kN	120	120	120
Max. speed	r.p.m.	1200	850	700
Recommended actuating cylinders*	type	DCE 140/140	DCE 140/140	DCE 140/140

\*technical details of DCE cylinders see page 230

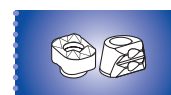

Page 310



Page 304



Page 217

# High precision 2+2 jaw power chuck with self-centering independent jaw movement Ø 500 - 800 mm

# TPT-C

- closed center
- tongue & groove

2+2 independent jaw movement  
Tongue & groove

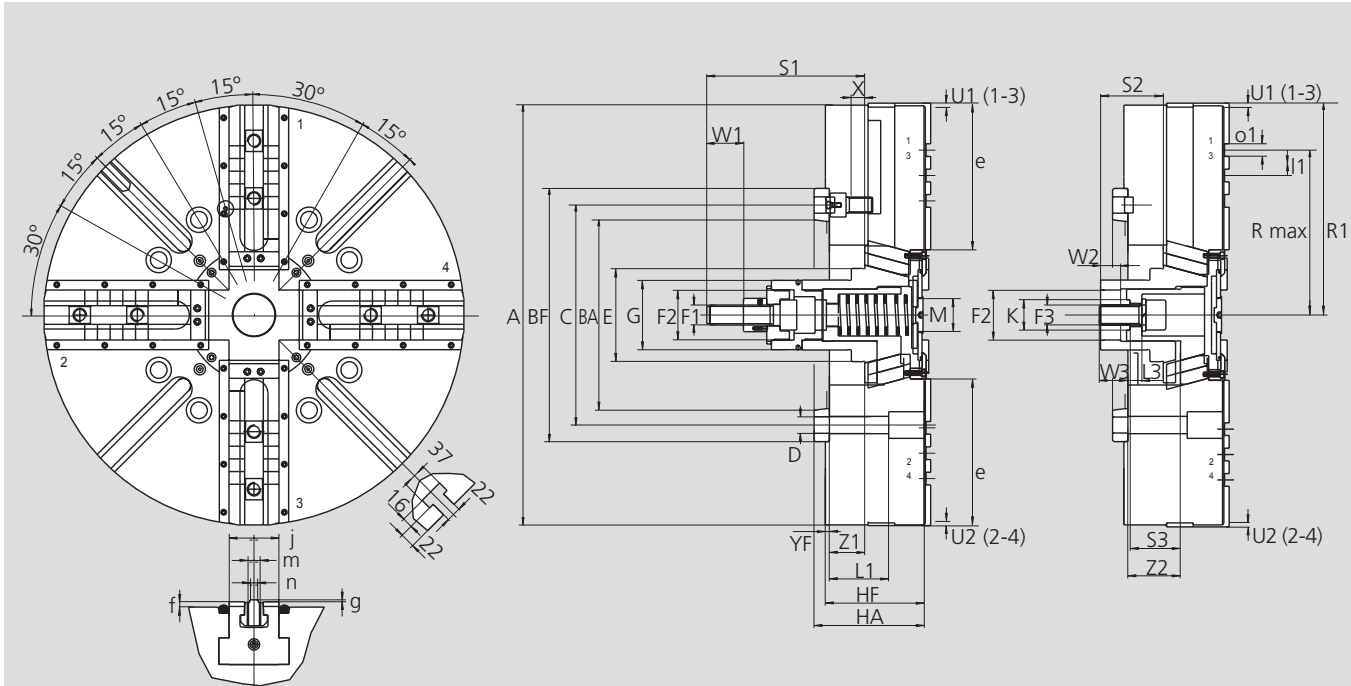

Subject to technical changes  
For more detailed information please ask for customer drawing

4

SMW-AUTOBLOK Type			TPT-C 500		TPT-C 630		TPT-C 800	
Mounting			Z380	A15	Z380	A15	Z380	A15
	A	mm		510		630		800
	Bf/BAH6	mm	380	285.775	380	285.775	380	285.775
	C	mm		330.2		330.2		330.2
	D	mm		25		25		25
	E	mm		140		140		140
	F1	mm		M30		M30		M30
	F2	mm		M75 x 2		M75 x 2		M75 x 2
	F3	mm		M30		M30		M30
	G	mm		104		104		104
Chuck height	Hf/HA	mm	130	147	150	167	150	167
	K	mm		45		45		45
	L1	mm		89		89		89
	L3	mm		18		18		18
	M	mm		M52 x 1.5		M52 x 1.5		M52 x 1.5
	R1	mm		263		318		405
	Rmax	mm		209.5		247.5		349
	S1	mm		237		237		237
	S2	mm		94		94		94
	S3	mm		76		76		76
Jaw stroke (power 1 + 3)	U1	mm		8.5		10		10
Jaw stroke (spring 2 + 4)	U2	mm		6.5		8		8
	W1	mm		55		55		55
	W2	mm		30		30		30
	W3	mm		46		46		46
	X	mm		20		20		20
	Yf/YA	mm		6/23		6/23		6/23
Wedge 1 max./min.	Z1	mm		33/1		53/15		53/15
Wedge 2 max./min.	Z2	mm		59/27		79/41		79/41
	e	mm		165		220		307
	f	mm		8		8		8
	g	mm		3		3		3
	j	mm		75		75		75
	l1	mm		38.1		38.1		38.1
	m	mm		20		20		20
	n	mm		12.7		12.7		12.7
	o1	mm		19.03		19.03		19.03